

## FRANCHISE FRUCOSOL SERVIZUMO

We would like to thank you the interest in our company asking for more information. We always work to be able to introduce the last technology in restaurants, hotels, and caterings...in a way our customers can offer a better service.

We are manufacturers of HORECA (Hotel, Restaurant and Catering) equipment since more than 20 years ago, so we have a great experience, know-how and knowledge that have led us to innovate with the commercial job, offering you this interesting BUSINESS OPPORTUNITY.

We have checked that an exploitation of our machines in the Horeca sector is one of the business opportunities with the highest possibilities of success and future any business man can find nowadays.

Our aim is to cover the National and International areas with a net of dealers that may carry out a FRUCOSOL Exploitation in their places.

We invite you to read carefully the following file and arrange an appointment to visit our headquarters in Calahorra, La Rioja (Spain) where we will show you our way of working and enhance the information you may need without any problem.

We look forward to hearing from you soon,

Regards,



Expanding Department

**FRUCOSOL**

# INDEX

## I.- INTRODUCTION

## II.- WHAT IS FRUCOSOL SERVICIUM?

## III. LEGAL PATTERN

## IV.- TECHNICAL CHARACTERISTICS

- MODEL JUICER F-50
- MODEL JUICER F-50 A
- MODEL JUICER F-Compact
- MODEL JUICER Self-Service
- MODEL JUICER Freezer

## V. NEEDS WE WANT TO COVER

## VI. NEWS AND COMPARATIVE ADVANTAGES

## VII. REQUIREMENTS FOR THE FRANCHISEE

- ESTABLISHMENT
- WORKERS
- FRANCHISEE APTITUDES

## VIII. CUSTOMERS AND COMPETENCE

## IX. COMERCIAL PLAN AND OBJECTIVES

## X. MAINTENANCE PLAN

## XI. FRUCOSOL SUPPORT

## XII. ATTACHMENTS

- TECHNICAL FILE F-50
- TECHNICAL FILE F-50 A
- TECHNICAL FILE F-Compact
- TECHNICAL FILE Self-Service
- TECHNICAL FILE Freezer
- WORKING TOOLS LIST
- EXHIBITIONS LIST

# I. INTRODUCTION

This file will show you the viability of setting up an exploitation of FRUCOSOL orange juicers, a leader company in this area since 1991.

As we know, it is highly recommended to follow a diet with a lot of fruit, and specially oranges due to its high level of C vitamin, something it will help us in the prevention of colds and other diseases.

Just taking two pieces of fruit should be enough to cover the recommended quantity of vitamins human being needs; the best way of doing it is with a glass of juice. Indeed orange juice is consumed since many years ago and its consumption is increased every year with the promotion of its qualities and benefits for the health.

Besides, we have to take into account that orange juice is an ideal drink, not only in summer but also in winter, and it is recommended for everybody.

So it is essential for any bar, hotel, restaurant, café...to offer fresh orange juice to their customers. Then we can find many types of orange juicers: manual, completely automatic, with a cooling system to control the temperature of the juices, with faucets, and so on...

Paying attention to this idea and together the fact that orange juices provide the owner of a establishment a high profit taking into account the price of the oranges, we have developed a new business based on the exploitation of these orange juicers.

## II. WHAT IS FRUCOSOL SERVICIZUMO?

The idea is based on the following: the owner of a local will have one machine without any cost with the condition of buying a set quantity of oranges every week or month. That is to say, the person who has the exploitation will become the supplier of oranges for that machine, being responsible of serving the fruit it needs one, two or three times every week, depending on the consumption.

Then, the person interested in this business needs an oranges supplier with a competitive price, so they should talk and agree with fruit wholesalers who will provide them with the quantity of oranges they need every day at a very good price; then, they won't need to make a big purchase of oranges to get the price it allows them to be competitive with the great supermarkets, and have in this way a good margin of benefit.

In this way, the franchisee won't need to store the fruit or buying refrigerators or coolers, something it will make our business more expensive. They will only have to serve the daily quantity the machines need.

FRUCOSOL just shows a business opportunity that is already working nowadays. As well, you will count with the support of a WELL-KNOWN BRAND in the National and International food service and catering business. Besides, the franchisee will have the advice of a technical and commercial department with the same interest of success than the one the franchisee may have.

### III. LEGAL PATTERN

FRUCOSOL will concede an exclusivity license for the commercial exploitation of the different Utility Models, Patents and Industrial Designs of the juicers F-50, F-50 A, F-Compact, Self-Service y Freezer. In this way, the franchisee will be the only legal dealer of these machines in the area it is set in any agreement.

The Franchise Identification Number (**NIFRA**) is **2009185217276 F**.

## IV. TECHNICAL CHARACTERISTICS

FRUCOSOL proposes 5 models from its range of automatic juicers to carry out this exploitation.

Each model is designed to cover different needs we find every day in the Horeca sector; design and functionality are mixed to get useful, attractive and lengthy machines.

All the models are finished in stainless steel. As well, the juicing process is made with a controlled pressure in a way the bitter substances of the orange remains on the peels.

### **Juicer mod. F-50 (Attachment 1)**

The F-50 stands out by its functionality, strength, and reliability and of course its profitability. It is an automatic machine that produces fresh orange juice with all the benefits of the C Vitamin.

### **Juicer mod. F-50 A (Attachment 2)**

The Frucosol F-50A stands out by its great efficiency and autonomy and it is ideal for those places where a big quantity of juice is consumed in a few time.

### **Juicer mod. F-Compact (Attachment 3)**

The F-compact is our smallest automatic juicer.

In a minimum space, the FCompact combines versatility, functionality and a design that makes it suitable for any type of business.

This model is recommended for establishments with a low demand of orange juice.

### **Juicer mod. Self-service (Attachment 4)**

The Frucosol Self-service stands out within our range of orange juicers for the presence of a faucet that makes the machine working. As well, we have installed in the stand cabinet a tray in order we can fill different sizes of glasses and bottles.

### **Juicer mod. Freezer (Attachment 5)**

In the Freezer model we have installed a cooling system and a 7 liters tank with a mixer and a no-drop faucet. It is perfect for the service in hotels, buffets and any restaurant with an important demand of juice.

## V. NEEDS WE WANT TO COVER

With this type of exploitation we want to avoid the task of the customer of going to the market to get the oranges, something that supposes an important waste of time.

This is a waste of time if we take into account that the customer has to go to the market almost every day to buy the orange, and often the price will be higher too. Frucosol Servizumo will solve that problem. But even, they won't have to buy an orange juice machine to be able to offer fresh juice as the franchisee will lend them a machine whenever they supply the customer with the oranges. The owner of the machine is the franchisee as we have already explained.

## VI. NEWS AND COMPARATIVE ADVANTAGES

The main comparative advantage with other similar systems is that Frucosol is the manufacturer of the machines, so we have a great experience about the product and the ways of selling it.

But why you should consider the option to associate to FRUCOSOL Servizumo? Above all because we are going to provide you with the technical training about the machines, the commercial training to install the machines in the lowest time, the training to develop the franchise, and of course advices from the Frucosol Team. As well, take into account that you will count with the support of our presence in the most important National and International Exhibitions of food service and catering equipment.

About this sector; Frucosol is manufacturing food service equipment since 1991. Then, we have been able to see, know and check its evolution since then. Indeed, this idea has arisen from our experience with customers and friends, so it is a question that we have developed to cover real necessities.

With regard to the machines, we can say that the main difference in comparison with our competitors is its manufacture in bright stainless steel. Its hygienic and aesthetical properties together with its resistance to corrosion make this material very attractive for the manufacture of food service and catering equipment.

## VII. REQUIREMENTS FOR THE FRANCHISEE

### **ESTABLISHMENT**

You won't need a commercial local (with the costs it would involve) to develop this Franchise as you don't need to show or store the machines. Frucosol will give you the option to send the machines when you need it.

### **WORKERS**

Just one person would be enough to carry out this business; he/she will be able to handle an exploitation of about 200 units.

But, once they have consolidated the business, with some customers, they will have important benefits every month so the commercial task won't be as intense as in the beginning. This will be the moment to decide if they want to increase the business or hiring some workers.

### **FRANCHISEE APTITUDES**

The franchisee must be pleasant with customers and a person with commercial aptitudes as the biggest part of the success will depend on his/hr capacity to treat the customers. We will provide you all the tools and commercial arguments you are going to need.

## VIII. CUSTOMERS AND COMPETENCE

The main customers we have to focus our attention to are hotels, restaurants, juice shops, caterings, hospitals, schools, caterings, coffee shops, geriatrics, colleges, and so on.

So there are many options, and taking into account the customer size and space possibilities, we should offer them one model of juicer or a different one.

This is a system you can already find nowadays, but the difference of Frucosol Servizumo is the training our franchisee will have before entering the market. We will provide you several fruit wholesalers in order you can negotiate the best price. As well you will also receive a commercial and technical training about the machines.

## IX. COMMERCIAL PLAN AND OBJECTIVES COMERCIALES

The commercial objective of the franchisee will be to install the machines of the exploitation.

Then the main task at the very beginning will consist of visiting several establishments of hostelry to let them know Frucosol Servizumo and its advantages.

In this first step we will focus our attention 100% in this commercial task.

Once we have installed the machines, we will pay more attention to the machines we have put than to the commercial task.

In any case, although our commercial task is lower and lower, it is very important to try to get new customers, so we could employ two or three days every week to get it. Besides, once we have some customers, we will get some others more easily due to the attraction our system will have in friends, competence and so on.

So summing up, the main marketing strategy will be:

- Informative visits to direct managers (or the person in charge)
- To use the experience of some customers as selling argument.
- Visit to Public and Private Institutions where you could get important agreements with Hotels Chains, Local Centers, Associations...

You will count with the Frucosol support to begin and develop this business. As our main objective is a professional customer, we must get the franchisee professional. In our course training we will show you some commercial techniques and technical training about the machines, its service and maintenance. Then, the commercial task should not be a limit for the Franchisee as Frucosol will help you in any moment.

## X. MAINTENANCE PLAN

The franchisee will become the supplier of the oranges the machine is going to need, and its main task will be to provide the customer with the oranges when they need it and at a price both have agreed.

The best way to contact with the customer is with a conversation with them and his/her workers in order to check if they have any doubt or comment, and give the answers to possible questions (something for which Frucosol would have trained) For any doubt you will have our support.

## XI. FRUCOSOL SUPPORT

The reason of the success of this system is the fact that covers the necessities many companies have. It allows the franchisee to join a strong group, with economic resources and then get advantage of our brand, the National and International marketing, advices...something it will help you to be successful in this business.

We will go with you in the future challenges:

- Guide to the customer to know and understand their needs.
- Agility to be adapted to possible changes and be ahead of requests.

We focus our attention to the quality and continuous improvement to look for the profit for both sides.

**FRUCOSOL** will put at your service:

- Training course in our warehouse in Calahorra with hotel and expenses.
- We will provide you with an e-mail address, on-line shop, and a laptop with the main tools to develop Frucosol Servizumo.
- As well, all our customers will have an After Sales phone to solve any possible doubt.
- Catalogues, brochures, technical files, visiting cards, stickers, posters, etc. (Attachment 6).
- Advertising we get from our presence in National and International Exhibitions (Attachment 7).
- Our products are approved with most important National and International certifications: The

European Rules and Conformity Declaration  and the Quality and Electrical Security

Certificate 

- We are part of the most important associations within this sector: Spanish Federation of Food Service and Catering Equipment Manufacturers  ; Spanish Export Manufacturers of Food Service and Catering Equipment Association  ; and European Federation of Catering Equipment Manufacturing **EFCEM**.

# MODELO F-50

F-50



EXPRIMIDORAS AUTOMÁTICAS  
para cítricos

AUTOMATIC JUICER MACHINES  
for citrus fruits





CARACTERÍSTICAS

Exprimidora totalmente automática de alimentación manual, para ofrecer zumo recién exprimido sin manipulación por parte del personal.

De diseño atractivo y construcción en acero inoxidable acabado en brillo, que le permite encajar en cualquier tipo de ambiente. No hay exprimidora más pequeña y más ligera que iguale sus prestaciones actualmente en el mercado.

Exprimidoras que aportarán a su negocio rentabilidad, ahorro de tiempo e imagen. La apertura frontal permite la visualización de todo el proceso, algo muy atractivo para los clientes que pueden ver el exprimido natural y comprobar su higiene, ya que es totalmente automático y no hay ningún tipo de manipulación. Nuestras exprimidoras garantizan un manejo sencillo y una limpieza rápida.



CHARACTERISTICS

Automatic juicer of manual feeding to offer fresh squeezed juice without manipulation.

It has an attractive design and is made of stainless steel, which makes it fit in any kind of atmosphere. There isn't any smaller and lighter machine that equalizes its technical features in the market currently. Automatic juicer machines that will provide your establishment with profits, time saving and nice image.

The front opening allows you the visualization of the squeezing process, something especially attractive for the customers that can see the natural squeezing and check the hygiene due to the fact it is completely automatic, and there is no manipulation at all. Our juicer machines guarantee you an easy handling and a fast cleaning.

FABRICAMOS SOLUCIONES PROVIDING SOLUTIONS

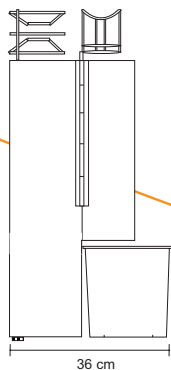
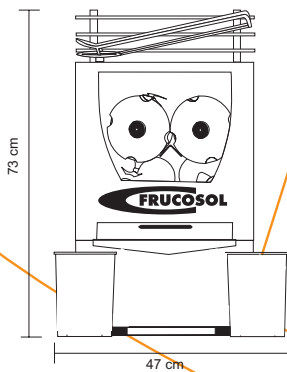

**F-50**

- **Consumo** 150 W
- **Motor** 3/4 CV
- **Voltaje** 230 - 110V 50 - 60Hz
- **Producción** 20 -25 frutas/min
- **Consumption** 150 W
- **Motor** 3/4 HP
- **Tamaño de la fruta** Hasta 85mm
- **Voltage** 230 - 110V 50 - 60Hz
- **Production** 20 - 25 fruits/min
- **Peso** 34 Kg
- **Fruit diameter** All sizes up to 85mm
- **Weight** 34 Kg
- **Seguridad** Sensores automáticos de apagado
- **Security** Automatic sensors of switching off

**F-50**  
**MODELO F-50**

# MODELO F-50 A



F-50-A

EXPRIMIDORAS AUTOMÁTICAS  
para cítricos

AUTOMATIC JUICER MACHINES  
for citrus fruits





CARACTERÍSTICAS

Totalmente automática y fácil de manejar, su sistema de funcionamiento no exprime la cáscara y le permite obtener un zumo natural sin restos de acidez. Gran rendimiento pues extrae el zumo y la pulpa queda en la corteza.

Este modelo cuenta con todas las características del F-50 y además incorpora un alimentador automático con una capacidad de almacenaje de 12 kg. El alimentador es circular y hecho en acero inoxidable brillante que le da un aspecto original y diferenciador del resto de equipos exprimidores.

Exprimidoras que aportarán a su establecimiento rentabilidad, ahorro de tiempo e imagen. Adaptables a cualquier negocio y a todo tipo de ambiente: panaderías, hornos, salones de té, coffee-shops, supermercados, fruterías, buffets de hoteles...



CHARACTERISTICS

It is completely automatic, easy to use, and its working system does not squeeze the peel and allows you to get a fresh juice without bitter remains. It provides you with a great efficiency because it gets the juice and the pulp remains in the peels.

This model has all the characteristics of the F-50 and it also incorporates an automatic feeder with a storage capacity for 12 kg. The feeder is circular and it is made of bright stainless steel which gives it an original and a different look from the other squeezer machines.

Automatic juicer machines that will provide your establishment with profits, time saving and good image. These can be adapted to any business and all the environments: Baker's shop, Tea saloons, Coffee-shops, Supermarkets, Hotels...

FABRICAMOS SOLUCIONES PROVIDING SOLUTIONS

PG. Tejerías Norte C/ San Lázaro s/n 26500 Calahorra ( La Rioja ) España

Tel. +34 941 147 653 Fax +34 941 148 519 frucosol@frucosol.com www.frucosol.com

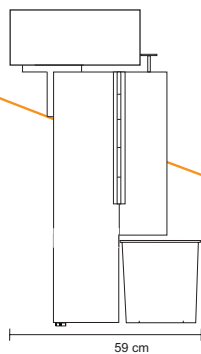
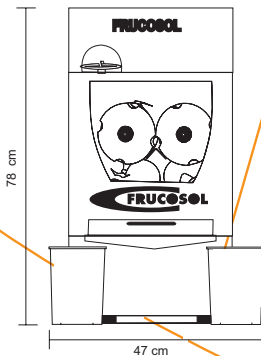

- **Consumo** 250 W
- **Motor** 3/4 CV
- **Voltaje** 230 - 110V 50 - 60Hz
- **Producción** 20 - 25 frutas/min
- **Consumption** 250 W
- **Motor** 3/4 HP
- **Voltage** 230 - 110V 50 - 60Hz
- **Producción** 20 - 25 fruits/min
- **Tamaño de la fruta** Hasta 80mm
- **Production** 20 - 25 fruits/min
- **Fruit diameter** All sizes up to 80mm
- **Peso** 44 Kg
- **Weight** 44 Kg
- **Seguridad** Sensores automáticos de apagado
- **Security** Automatic sensors of switching off

F-50 A

MODELO F-50 A

# MODELO F-Compact

F-Compact



EXPRIMIDORAS AUTOMÁTICAS  
para cítricos

AUTOMATIC JUICER MACHINES  
for citrus fruits





CARACTERÍSTICAS

La F-Compact es nuestro modelo de exprimidor automático más pequeño y compacto.

En un mínimo de espacio la F-Compact reúne versatilidad, funcionalidad y un diseño muy atractivo que la hacen adaptarse a cualquier tipo de negocio. La apertura frontal permite ver el proceso de exprimido, algo muy atractivo para el cliente.

Fabricada en acero inoxidable y utilizando materiales de alta calidad que hacen de su durabilidad, uno de sus puntos fuertes.

Este modelo está recomendado para establecimientos con una demanda baja de zumo de naranja.



CHARACTERISTICS

The F-Compact is our new automatic juicer, being smaller and compacter then the previous ones.

In a minimum space, the F-Compact combines versatility, functionality and a design that makes it suitable for any type of business. The front cover allows seeing the squeezing process, something very interesting for the customers.

It is made in stainless steel, using high quality materials, so we could say that " long-life" is one of its strong points.

This model is recommended for establishments that doesn't have too much demand of orange juice.

FABRICAMOS SOLUCIONES PROVIDING SOLUTIONS

PG. Tejerías Norte C/ San Lázaro s/n 26500 Calahorra ( La Rioja ) España Tel. +34 941 147 653 Fax +34 941 148 519 frucosol@frucosol.com www.frucosol.com

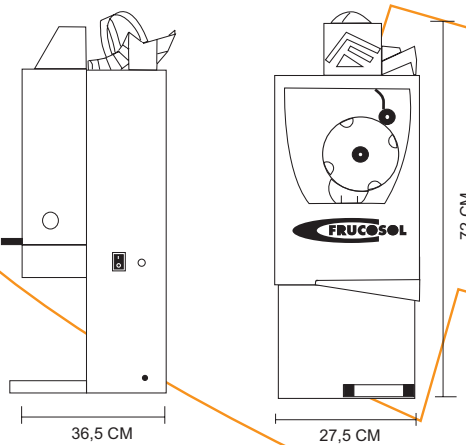

- Consumo 150 W
- Voltaje 230 - 110V 50 - 60Hz
- Producción 10 - 12 frutas/min
- Consumption 150 W
- Voltage 230 - 110V 50 - 60Hz
- Production 10 - 12 fruits/min
- Tamaño de la fruta Hasta 70 mm
- Fruit diameter All sizes up to 70 mm
- Peso 25 Kg
- Weight 25 Kg



F-Compact

MODELO F-Compact

MODELO SELF-SERVICE

SELF-SERVICE



EXPRIMIDORAS AUTOMATICAS  
*para cítricos*

AUTOMATIC JUICER MACHINE  
*for citrus fruit*



## CARACTERÍSTICAS

Este modelo de exprimidor Frucosol se caracteriza por la incorporación de un grifo que permite la puesta en marcha y su parada del proceso de exprimido simplemente presionándolo. Así los clientes pueden disfrutar al instante del zumo recién exprimido de la forma más cómoda y sencilla.

El modelo Self- Service al igual que todos los demás exprimidores Frucosol, está fabricado en acero inoxidable en brillo de alta calidad, que hacen que su durabilidad sea uno de sus puntos fuertes.

El mueble contenedor incorpora una rejilla posavasos regulable en altura gracias a la cual el llenado de vasos o botellas de diferentes dimensiones no supondrá problema alguno. Gracias a esto, este modelo es ideal para supermercados, hoteles, buffets, caterings...etc

## CHARACTERISTICS

This Frucosol orange juicer is characterized because just pressing its faucet the squeezing mechanism will start to work. Then the customers will have fresh orange juice in seconds and in the most comfortable and easy way.

The Self- Service model, as all the Frucosol orange juicers, is made of bright High Quality Stainless Steel; in that way, we can say without any problem that long-life is one of its strong points.

The stainless steel cabinet has a glasses rack that whose position can be adjusted; thanks to it the filling of glasses or bottles of different dimensions will not be a problem for the user. Then, this is an ideal machine for hotels, buffets, caterings or supermarket.

## FABRICAMOS SOLUCIONES PROVIDING SOLUTIONS

PG. Tejerías Norte  
C/ San Lázaro s/n  
26500 Calahorra  
( La Rioja ) España

Tel. +34 941 147 653  
Fax +34 941 148 519  
frucosol@frucosol.com  
www.frucosol.com

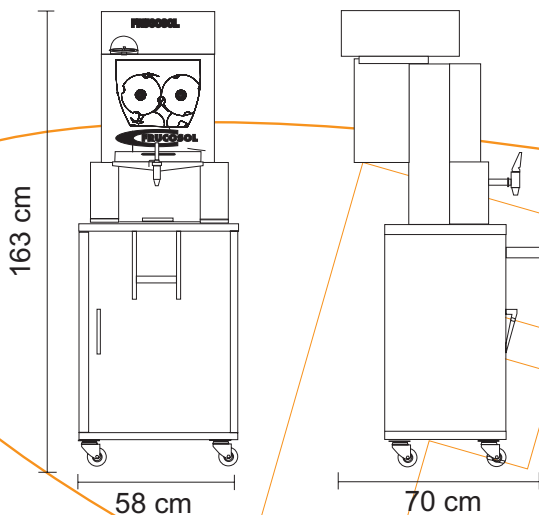

- Consumo 250 W
- Producción 20 -25 frutas/min
- Consumption 250 W
- Production 20 - 25 fruits/min
- Capacidad Alimentador 12 Kg
- Feeder Capacity 12 Kg
- Peso 90,5 Kg
- Weight 90,5 Kg
- Seguridad Sensores automáticos de apagado
- Security Automatic sensors of switching off

SELF-SERVICE

MODELO SELF-SERVICE

# FREEZER

## MODELO FREEZER



EXPRIMIDORAS AUTOMATICAS  
*para cítricos*

AUTOMATIC JUICER MACHINES  
*for citrus fruits*





### CARACTERÍSTICAS

Exprimidora totalmente automática fabricada en acero inoxidable, muy robusta, con alimentador con una capacidad de almacenamiento de 12 kg de naranjas. El modelo Freezer incorpora un equipo de frío con depósito dentro del mueble con capacidad para 7 litros de zumo que incorpora un agitador y un grifo antigoteo. La temperatura de conservación es regulable entre 1° y 7° C.

Ideal para ser utilizado tanto por personal del establecimiento como el consumidor final. Este completo equipo incorpora un mueble contenedor también en acero inoxidable para los desperdicios, que le dota de una gran autonomía y movilidad.

Son el complemento perfecto para el servicio de hoteles, buffets y restauración en general, con una gran demanda de zumo.



### CHARACTERISTICS

This is automatic orange juice machine completely made in stainless steel; it is a very strong machine provided with an automatic feeder with a capacity of 12 kgs. The Freezer model has a cooler in a 7 litres tank that includes a waver and no-drip faucet. The temperature can be adjustable between 1° and 7° C.

This model is ideal to be used either by staff of the establishment or by the end user. This complete equipment is served with a stainless steel cabinet for the peels too, so a great autonomy is one of its main characteristics.

It is the perfect partner for the service in hotels, buffets and horeca sector with an important request of juice.

## FABRICAMOS SOLUCIONES PROVIDING SOLUTIONS

PG. Tejerías Norte  
C/ San Lázaro s/n  
26500 Calahorra  
( La Rioja ) España

Tel. +34 941 147 653  
Fax +34 941 148 519  
frucosol@frucosol.com  
www.frucosol.com

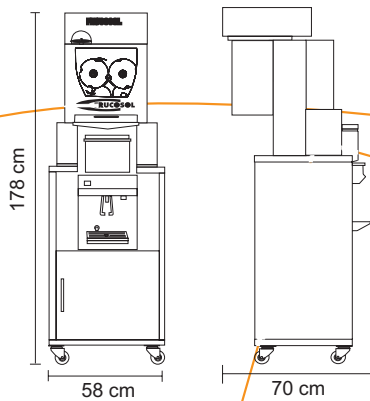

- **Consumo**  
400 W
- **Consumption**  
400 W
- **Producción**  
20 -25 frutas/min
- **Production**  
20 - 25 fruits/min
- **Capacidad Alimentador**  
12 Kg
- **Feeder Capacity**  
12 Kg
- **Peso**  
117 Kg
- **Weight**  
117 Kg
- **Seguridad**  
Sensores automáticos de apagado
- **Security**  
Automatic sensors of switching off

**FREEZER**  
**MODELO FREEZER**

Los diseños y especificaciones de los productos mostrados en este catálogo están sujetos a cambiar sin previo aviso. We reserve the right to make changes in desing and/or engineering without notice.

## ATTACHMENT 6: WORKING TOOLS LIST

- 35 machines model F-50 (it can be mixed with the rest of our juicers).
- On-line shop.
- E-mail address within the server franquicia-frucosol.com
- Option to sell other **Frucosol** products (according to a Clause in the Agreement).
- Laptop with the main tools to develop the business.
- Visiting cards: 500 units
- General catalogue: 100 units
- Brochures: 600 units
- Frucosol folders to give the information and budgets: 400 units.
- Frucosol envelopes: 1.000 units
- Hotel for 2 people during the Training Course\*\* in Calahorra.
- Expenses during the Course.
- Stickers in the vehicle.
- Standard Agreements to carry out the activity.
- Help of a salesman
- National and International Advertising in Exhibitions of Food service Equipment and Franchises.

*(\*\*)The training course will consist of:*

- Technical information about the machines F-50, F-50-A, F-Compact, Self-Service y Freezer.
- Ways of selling it.
- Computer Training.

## ATTACHMENT 7: EXHIBITIONS LIST

**ALIMENTARIA y HOSTELCO** - Barcelona

**GOURMETS Y HOREQ** - Madrid

**HOSTELEQUIP** - Málaga

**GULF FOOD** - Dubai

**FHA** - Chicago

**HOREXPO** - Lisboa

**HOST** - Milán

**SIF & CO** - Valencia

**EXPOFRANQUICIA** - Madrid

**FRANCHISE EXPO PARIS** - París

**TO GET THE FINANCIAL PLAN AND ECONOMICAL  
DETAILS PLEASE CONTACT US**

***CENTRAL WAREHOUSE:***

**POL. IND. TEJERÍAS NORTE C/ SAN LÁZARO S/N**

**26500. CALAHORRA. LA RIOJA**

**PH. + 34 941 147 653**

**FAX. +34 941 148 519**

**[info@franquicia-frucosol.com](mailto:info@franquicia-frucosol.com)**

**[www.franquicia-frucosol.com](http://www.franquicia-frucosol.com)**